

CHECK VALVE SERIES

止回阀系列



Industrial Piping System
Solutions Expert
工业管道系统解决专家

www.jtong.cn
www.jiutongvalve.com

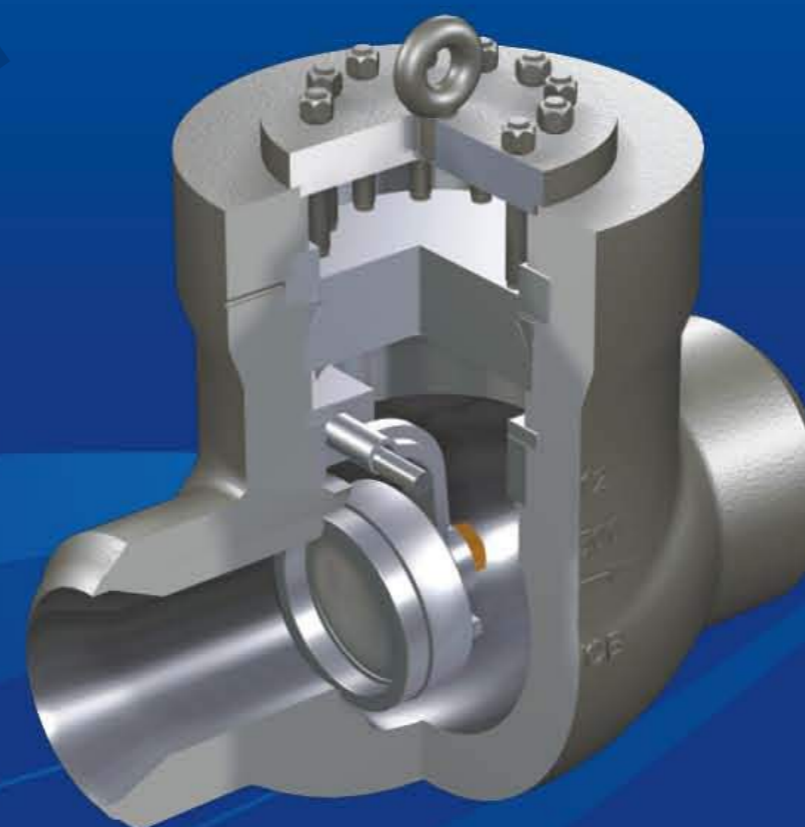

中国·九通集团有限公司
CHINA · JIUTONG GROUP CO.,LTD.

地址：江苏滨海经济开发区瓠北泵阀工业园
电话：0515-89118277 89118377 89118577 89118677
传真：0515-89118000
邮编：224500

Add: Oubei pump & valve industry Park North District, Binhai
Economic Development Zone, Jiangsu province
Tel: 0515-89118277 89118377 89118577 89118677
Fax: 0515-89118000
P.C: 224500

www.jtong.cn www.jiutongvalve.com

©九通企业 (JIUTONG INDUSTRY) 版权所有 采用生态纸印刷
*特别声明：本资料数据由中国·九通集团有限公司负责解释，如有参数变更，恕不另行通知。不详之处请向我公司垂询！

诚招代理商 Recruitment Agents:

中国·九通集团有限公司
CHINA · JIUTONG GROUP CO.,LTD.

企业简介

Brief Introduction

www.jitong.cn
www.jitongvalve.com



诚信立业、追求卓越
Setting Up Business
In Good Faith, Seeking
For Excellence

中国·九通集团有限公司是集研发、制造、销售各种阀门为一体的大型综合性阀门企业。是中国阀门协会会员，国家电力公司电站配件供应网络成员，中国工程建设推荐产品单位。公司先后通过了ISO9001(DNV)、环境管理ISO14001、职业健康安全OHSAS18001、美国石油协会API-6D认证、欧盟安全CE认证、压力管道安全注册TS认证。

公司总部占地62800平方米，建筑面积43960平方米，现有员工200多人，其中高级工程师16人，中级技术人员56名。公司依托国外先进的技术支持和高效的管理，为生产高品质的产品提供了强有力的保证。投资兴建的工业园内建有热模锻、精密铸造、焊接、热处理、机械加工、装配等车间；拥有数控加工中心、等离子焊接机、超频真空热处理设备、车球专用数控、高效加工专机、理化和探伤设备、无损探伤检测中心等各类加工检测设备300多台套，设备配置齐全、加工检测手段完备。公司建立有CAD阀门设计中心，三维立体模拟制造实验设计系统、公司设备完备的质保系统，按照ISO9000的管理标准，从原材料进厂的产品出厂，实行道工序层层把关，确保产品质量。

公司产品按国际ISO、美国API、ANSI、英国BS、德国DIN、法国NF、日本JIS、JPI、及GB、JB标准组织生产，阀门主要

产品有电站阀、闸阀、截止阀、止回阀、球阀、蝶阀、水力控制阀、锻钢阀、疏水阀、船用阀门、机械铸造、机械锻造、试验及检验设备等；压力级：Class150-class4500，PN10-PN420；口径范围：NPS1/2-NPS80，DN10-DN3000；驱动方式：手动、齿轮传动、气动、电动、气液联动等；连接方式：法兰连接、对焊连接、承插连接、对夹连接、螺纹连接、卡套连接等；主要材料（铸件）：WCB、WCC、LCB、LCC、LC1、LC2、LC3、CF8、CF3、CF8M、CF3M、CF8C、CN7M、CA15、C5、WC5、WC6、WC9等；主要材料（锻件）：A105、LF1、LF2、F304、F304L、F316、F316L、F11、F22、F6、F51、F316H、F321、F347等。并根据客户特殊要求进行冶炼和制造。多年来为电力、石油、化工、化肥、冶金、制药等行业引进装置进行阀门配置，产品畅销2000多家大中型企业，并致力开拓国际市场，已出口阀门数万（台）套，远销欧美、中东、东南亚等十多个国际和地区，得到用户的广泛赞誉和信赖。

展望未来，我们将与时俱进，锐意创新，时刻满怀创业的豪情和无限憧憬，昂首阔步，纵横千里，实行着又一个新的跨越。同时竭诚期待各界销售精英加盟，共建九通经销商网络，我们将以最优性价比的产品和服务，最富竞争的商务政策、回馈销售网络，与经销商朋友共谋发展，共赢未来。

China Jiutong Group Corporation is a large-scale comprehensive enterprise integrating R&D, manufacturing and sales of various valve, and one of the members of China Valve Association, State Power Corporation Power Station Accessories Supply Network and the recommending products list of Chinese engineering construction. It has passed successively the following certifications like ISO9001(DNV), Environmental Management ISO14001 and Occupational Health and Safety OHSAS18001, API-6D, CE and TS for Pressure Pipeline Safety Registration.

The corporation covers an area of 62800 sq.m, and a floorage of 43960 sq.m with a staff of more than 200 involving 16 senior engineers and 56 middle-grade technicians. A powerful assurance is offered to produce high quality products based upon foreign advanced technical support and high efficient management, the industry park invested has constructed the workshops of hot-press forging, precision casting, welding, heat treatment, mechanical processing, assembling and so on and has complete equipments and testing measures in possession of over 300 sets of various processing and testing equipments like CNC processing center, plasma welding machine, ultra-frequency vacuum heat treatment machine, ball-purpose CNC and efficient processor, physical & chemical detection machine, nondestructive inspection machine and so on. It has established CAD valve design center, three-dimensional Analogue manufacturing experimental design system and complete quality control system with armed equipments. The quality of products is guaranteed in each work procedure from the entrance of raw materials to the delivery of products in accordance with the standards of ISO9000.

The products, produced in accordance with ISO, API, ANSI, BS, DIN, NF, JIS, JPI, GB and JB, include power station valve,

gate valve, globe valve, check valve, ball valve, butterfly valve, hydraulic valve, forged steel valve, drainage valve, boat-purpose valve, mechanical forging, mechanical casting, testing and examination equipments etc., under the pressure classes from Class150 to class 4500 (PN10-PN420), the diameter ranging from NPS 1/2 to NPS80 (DN10-DN3000), they are driven by the modes of manually, gears, pneumatically, electrically, pneumatically-hydraulically and the connection modes like flange, butt-welding, socket, wafer, threads, sleeve and so on, and made of the following materials (casting parts): WCB, WCC, LCB, LCC, LC1, LC2, LC3, CF8, CF3, CF8M, CF3M, CF8C, CN7M, CA15, C5, WC5, WC6, WC9 and so on, and main materials (forging parts): A105, LF1, LF2, F304, F304L, 316, F316L, F11, F22, F6, F51, F316H, F321, F347 and so on, furthermore, the products can be melt and manufactured as per special requirements of clients, which are used to configure the valves of the introducing device in the fields like power supply, petroleum, chemicals, fertilizer, metallurgy and pharmacy, and are well sold to more than 2000 large and middle-scale enterprises and strive for exploiting international markets by exporting ten thousands of valves to ten odd nations and regions including Western countries, Middle East and Southeast Asia, and are widely trusted and appraised by clients.

Looking forward to the future, we will keep pace to the times and innovation, take a leap of new summit with full ambition and expectation of enterprising, moreover, we are sincerely looking forward to the joining of sales elite in various cycles to commonly develop dealer network of Jiutong, we will commonly make development and win-win policies with friends of dealers on the basis of products and service of best cost performance and most competitive business policies and the feedback of sales network.

品质保障 Quality Guarantee

品质，是核心理念！

我们将品质融入企业运行的每一环节，赋予现实的表现。
品质之路，积跬步，至千里，济天下，
立志成为值得人们信赖的阀门品牌企业。

Quality, the Kernel Concept.

We have inoculated the quality into each step of enterprise management, not a slogan only.
The way of quality development, is accumulated step by step, then it can glow up long time,
win the world market.
We aspired to become the reliable brand of valve appliances.



我们珍惜用多年汗水铸造的品牌，珍惜每一份来之不易的荣誉。面对掌声我们没有眷恋徘徊，也不曾犹豫不决，
我们把它化作前进的动力，一步一脚印、不断锐意进取、超越自我……
We cherish the brand casted by sweat and every hard-earned honor. Facing applause,
We never wandered and hesitated. We turn it into the power pushing us forward step by step……

完善的检测保障系统 Completed Inspection Guarantee System



生产装备 Production Equipment

我们拥有先进的生产装备，运用崭新的管理概念及强大的专业技术力量，生产出符合国际标准的高品质产品。

We Own Advanced Producing Equipment ,make Sure Of Completely New Managing Concept An Strong Professional Technology Force To Produce High Quality Products That Confirm With International Standard.

先进的加工设备，可靠的质量保证。一流的检测设备，一丝不苟的检测手段，确保产品的稳定和可靠。细致是监测产品质量的保证。不让质量问题损害我们的品牌是我们的宗旨。有序的生产程序，有效的工作效率是取胜于一切的必要基础。

Advanced processing equipment, reliable quality guaranty best checking equipment, earnest checking measures, macking sure of the steadiness and reliane of our products. Meticulous monitoring is the assurance of product quality. We never allow quality defect injuring our brand. Orderly production process and effective working efficiency is quite crucial for making success.

>>>>

>>>>

>>>>

>>>>



产品目录 Contents

>>>>

止回阀	01-02	Check Valve	01-02
旋启式止回阀	03-08	Swing Check Valve	03-08
升降式止回阀	09-11	Piston-lift Type Check Valve	09-11
API 电站旋启式止回阀	12-13	API Power Station Swing Check Valve	12-13
GB 电站止回阀	14-16	GB Power Station Check Valve	14-16
水压试验阀	17-18	Water Pressure Test Valve	17-18
抽气止回阀	19-20	Extraction Check Valve	19-20
空排止回阀	21	Empty Row Check Valve	21
锻钢立式升降止回阀	22	Forging Vertical Lift Check Valve	22
对夹立式止回阀	23	Wafer Type And Vertical Lift Check Valve	23
保温夹套止回阀	24-25	Steam Jacket Check Valve	24-25
H4 ¹ / ₃ WA-220/320Roo、A、P型升降式止回阀	26	H4 ¹ / ₃ WA-220/320Roo、A、P Type Piston-lift Type Check Valve	26

www.jtong.cn
www.jiutongvalve.com

止回阀 Check Valve



● 型号编制说明 Model schedule illustration



结构特征代号: 栓接阀盖结构(省略) Ps—压力密封结构
Feature code: Bolt-jointed bonnet structure omitted Ps—Pressure sealed structure

阀门类型代号: H—止回阀
Valve type code: H—Check valve

连接形式代号: 1—内螺纹 2—外螺纹 4—法兰 6—焊接 7—对夹 8—承插焊
Connecting type code: 1—Interior whorl 2—Other whorl 4—Flange 6—Welding 7—To inserting 8—Bear and insert welding

结构形式代号: 1—升降式 2—升降立式 4—单瓣旋启式 6—双瓣旋启式
Design feature code: 1—Lifting type 2—Lifting vertical type 4—Single-disc swing type 6—Dual-disc swing type

密封面材质代号: Y—硬质合金 H—合金钢 X—橡胶 F—聚四氟乙烯
Sealing formation code: Y—Hard alloy H—Alloy steel X—Rubber F—Polytetrafluoroethylene (PTFE)

压力等级代号: 公称压力为MPa的10倍、磅级为实际数
Pressure grade code: The 10 times of the nominal pressure MPa, pound grade is practical number

阀体材料代号(国标材质代号与下列相应材质代号等同):

(1)铸造阀体: C—WCB I—WC6、ZG1Cr5Mo V—WC9、ZG20CrMoV P—CF8、ZG1Cr18Ni9Ti
R—CF8M、ZG1Cr18Ni12Mo2Ti S—CF3 L—CF3M F—LCB N—LC3

(2)锻造阀体: C—A105 E—LF2 A—F11 V—F22 P—F304 R—F316 S—F304L L—F316L

Body material code: (1) Cast the valve body: C—WCB I—WC6、ZG1Cr5Mo V—WC9、ZG20CrMoV P—CF8、ZG1Cr18Ni9Ti
R—CF8M、ZG1Cr18Ni12Mo2Ti S—CF3 L—CF3M F—LCB N—LC3

(2) Forge the valve body: C—A105 E—LF2 A—F11 V—F22 P—F304 R—F316 S—F304L L—F316L

● 产品结构特点 Products design features

止回阀适用于压力PN1.6~42.0MPa(Class150~4500), 工作温度-196~600°C的石油、化工、制药、化肥、电力行业等各种工况的管路上, 防止介质的倒流。

Check valves are used in pipes under pressures between PN1.6~42.0MPa(Class150~4500Lb), working temperatures -196~600°C, They are used in industries include oil, chemistry, pharmaceutical, fertilizer, and power generation to prevent the backward flux of the media.

● 其主要结构特点有 The main structure features include

- 1、产品结构合理、密封可靠、性能优良、造型美观。
The products feature a reasonable structure, reliable seal, good performance and nice modeling.
- 2、产品可根据不同的工况选择软质密封或硬质密封。密封面堆焊Co基硬质合金, 耐磨、耐蚀、抗擦伤性能更好, 使用寿命长。
Either soft or hard seal can be selected for the product upon different working conditions. The sealing face is built up with Co-based carbide alloy, leaving a better wearability, corrosion and scrap resistance and a longer duration.
- 3、开启压力小, 阀瓣在很小的压差下就能完全打开。
Small opening pressure, the disc can be opened fully with a very small pressure differential.

- 4、内装式的销轴结构，减小外泄漏点，使用可靠。
Inside-set bolt-bearing structure reduces leakage and reliable use.
- 5、公称压力 $\geq 16.0\text{MPa}$ (Class1500) 中腔采用自紧式密封结构，密封性能随压力升高而增强，保证了密封性能。
 $\text{PN} \geq 16.0\text{Mpa}$ (class1500), the middle cavity uses a self-tightening sealing structure to have the sealing performance reinforced along with the pressure rise so as to ensure the sealing performance.
- 6、零件材质及法兰、对焊端尺寸可根据实际工况或用户要求合理选配，满足各种工程需要。
Different parts materials and different sizes for flange, butt-welding are available for sensible combination according to different working facts and customers' requirements.

● 产品主要参数 Main parameter of the products

基本型号 Serial models	(Ps)H44H(Y)、(Ps)H64H(Y)、(Ps)H41H(Y)、(Ps)H61H(Y)、(Ps)H42H(Y)、(Ps)H62H(Y) (Ps)H74H(Y)、(Ps)H71H(Y)、(Ps)H76H(Y)、(Ps)H72H(Y)
压力等级范围 Pressure grade range	PN1.6~42.0MPa (Class150~4500)
口径范围 Drift diameter range	DN15~1000mm(1/2"~40")

● 产品性能规范 Products performance specification

压力等级 Pressure	常温试验压力(MPa) Testing pressure at constant temperature (Mpa)		适用温度 Applicable temperature	适用介质 Applicable medium
	壳体试验 The shell testing	密封试验 Seal and test		
公称压力 (MPa) Nominal rating pressure (PN)	1.6	2.4	-196~600°C	水、油品、蒸汽等 Water, oil, steam, etc.
	2.5	3.75		
	4.0	6.0		
	6.4	9.6		
	10.0	15.0		
磅级(Lb) Pound grade (Class)	16.0	24.0	-196~600°C	水、油品、蒸汽等 Water, oil, steam, etc.
	25.0	37.5		
	150	3.0		
	300	7.5		
	600	15.0		
	900	22.5	-196~600°C	水、油品、蒸汽等 Water, oil, steam, etc.
	1500	37.5		
	2500	63.0		
		46.2		

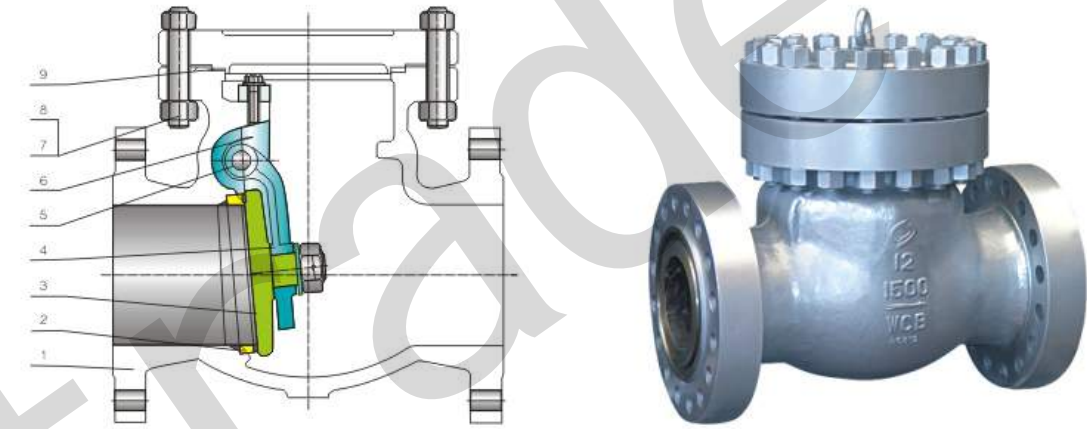

● 产品采用标准 Technical specification

结构形式 Structural formation	栓接阀盖旋启式止回阀 Bolt-jointed bonnet swing type check valve	
设计依据 Design reference	GB	API
设计标准 Design standard	GB/T 12236	API 6D
结构长度 Face to face	GB/T 12221	API 6D、ASME B16.10
连接法兰 Flanged ends	JB/T 79	ASME B16.5
试验和检验 Test & inspection	JB/T9092	API 598

注：阀门连接法兰及对焊端尺寸可根据用户要求设计制造。
Notes: The sizes of valve connecting flange and butt-welding terminas can be designed according to customer's requirement.

● 主要零件材料 Major parts material form

序号 No.	零件名称 Part name	材质 Material	
		ASTM	GB
1	阀体 Body	WCB, WC1, WC6, WC9, C5 CF8, CF8M, CF8C, CF3, CF3M	WCB, WC1, WC6, WC9, C5 CF8, CF8M, CF8C, CF3, CF3M
2	阀座 Seat	A105, F11, F22, F5, F9 F304, F316, F321, F304L, F316L	25, 1Cr13, 2Cr13 1Cr18Ni9Ti, 0Cr18Ni12Mo2Ti, 20Cr1Mo1V, 25Cr2MoV
3	阀瓣 Disc	WCB, WC1, WC6, WC9, C5 CF8, CF8M, CF8C, CF3, CF3M	WCB, WC1, WC6, WC9, C5 CF8, CF8M, CF8C, CF3, CF3M
4	摇杆 Rocker	WCB, WC1, WC6, WC9, C5 CF8, CF8M, CF8C, CF3, CF3M	WCB, WC1, WC6, WC9, C5 CF8, CF8M, CF8C, CF3, CF3M
5	销轴 Pivot	Gr.F6a, F22 F304, F316, F321, F304L, F316L	1Cr13, 2Cr13 1Cr18Ni9Ti, 0Cr18Ni12Mo2Ti
6	连接架 Join the shelf	WCB, WC1, WC6, WC9, C5 CF8, CF8M, CF8C, CF3, CF3M	WCB, WC1, WC6, WC9, C5 CF8, CF8M, CF8C, CF3, CF3M
7	双头螺栓 Stud	A193-B7, A320-B8, A193-B8M	35CrMoA, 25Cr2MoV, 0Cr18Ni9, 0Cr17Ni12Mo2
8	六角螺母 Six angle nuts	A194-2H, A194-B, A194-8M	45, 35CrMoA, 25Cr2MoV, 0Cr18Ni9, 0Cr17Ni12Mo2
9	垫片 Gasket	柔性石墨+不锈钢 Graphite & stainless steel	柔性石墨+不锈钢 Graphite & stainless steel

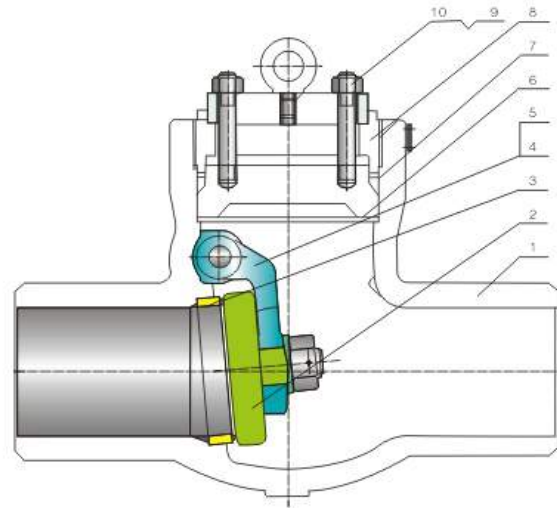

● 产品采用标准 Technical specification

结构形式 Structural formation	压力密封旋启式止回阀 Pressure sealed swing type check valve	
设计依据 Design reference	GB	API
设计标准 Design standard	GB/T 12236	API 600
结构长度 Face to face	GB/T 12221	ASME B16.10
连接法兰 Flanged ends	JB/T 79, GB/T 9113, HG20594	ASME B16.5
对焊端 Butt-welding ends	GB/T 1224	ASME B16.25
试验和检验 Test & inspection	JB/T9092	API 598

注：阀门连接法兰及对焊端尺寸可根据用户要求设计制造。
Notes: The sizes of valve connecting flange and butt-welding terminas can be designed according to customer's requirement.

● 主要零件材料 Major parts material form

序号 No.	零件名称 Part name	材质 Material	
		ASTM	GB
1	阀体 Body	WCB, WC1, WC6, WC9, C5 CF8, CF8M, CF8C, CF3, CF3M	WCB, WC1, WC6, WC9, C5 CF8, CF8M, CF8C, CF3, CF3M
2	阀瓣 Disc	WCB, WC1, WC6, WC9, C5 CF8, CF8M, CF8C, CF3, CF3M	WCB, WC1, WC6, WC9, C5 CF8, CF8M, CF8C, CF3, CF3M
3	阀座 Seat	A105, F11, F22, F5, F9 F304, F316, F321, F304L, F316L	25, 1Cr18Ni9Ti, 0Cr18Ni12Mo2Ti 20Cr1Mo1V, 25Cr2MoV
4	销轴 Pivot	Gr.F6a, F22 F304, F316, F321, F304L, F316L	1Cr13, 2Cr13 1Cr18Ni9Ti, 0Cr18Ni12Mo2Ti
5	摇杆 Rocker	WCB, WC1, WC6, WC9, C5 CF8, CF8M, CF8C, CF3, CF3M	WCB, WC1, WC6, WC9, C5 CF8, CF8M, CF8C, CF3, CF3M
6	阀盖 Bonnet	A105, F11, F22, F5, F9 F304, F316, F321, F304L, F316L	25, 1Cr18Ni9Ti, 0Cr18Ni12Mo2Ti 20Cr1Mo1V, 25Cr2MoV
7	密封圈 Sealing ring	柔性石墨 Graphite	柔性石墨 Graphite
8	压盖 Cover	WCB, WC1, WC6, WC9, C5 CF8, CF8M, CF8C, CF3, CF3M	WCB, WC1, WC6, WC9, C5 CF8, CF8M, CF8C, CF3, CF3M
9	双头螺柱 Stud	A193-B7, A320-B8, A193-B8M	35CrMoA, 25Cr2MoV, 0Cr18Ni9, 0Cr17Ni12Mo2
10	六角螺母 Six angle nuts	A194-2H, A194-8, A194-8M	45, 35CrMoA, 25Cr2MoV, 0Cr18Ni9, 0Cr17Ni12Mo2

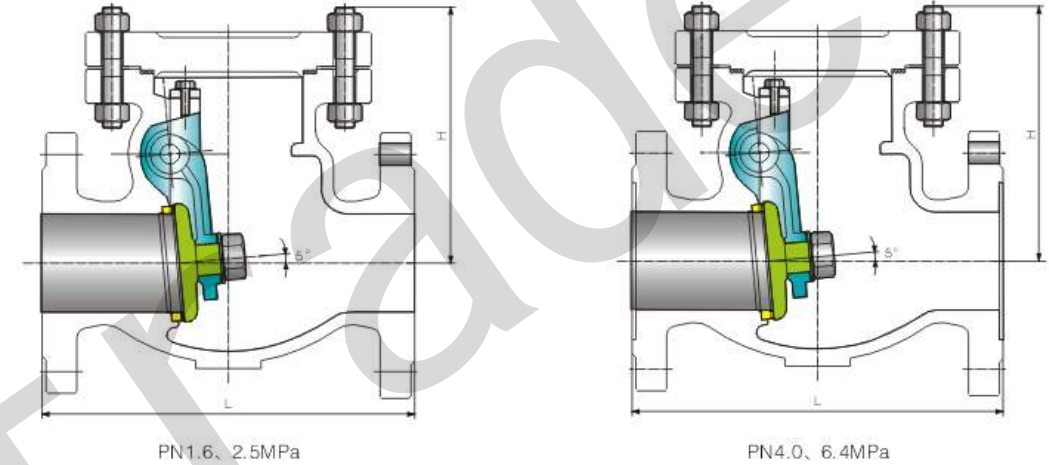

● 主要外形尺寸及重量 Main size of outside & weight

型号 Model: H44H, H44Y

PN (MPa)	DN (mm)	尺寸 Dimensions (mm)		重量 Weight (kg)
		L	H	
1.6	50	230	165	23
	65	290	180	28
	80	310	190	35
	100	350	208	40
	150	480	270	81
	200	550	295	96
	250	650	337	175
	300	750	386	265
	350	850	430	364
	400	950	475	495
2.5	500	1150	565	590
	50	230	180	25
	65	290	195	32
	80	310	195	35
	100	350	220	55
	150	480	273	104
	200	550	352	138
	250	650	413	198
	300	750	432	388
	350	850	455	390
4.0	400	950	562	498
	500	1150	620	643
	50	300	195	32
	65	340	213	45
	80	380	213	50
	100	430	240	75
	150	550	302	158
	200	650	362	220
	250	775	410	346
	300	900	468	476
6.4	350	1025	520	630
	400	1150	572	886
	500	1400	625	1030

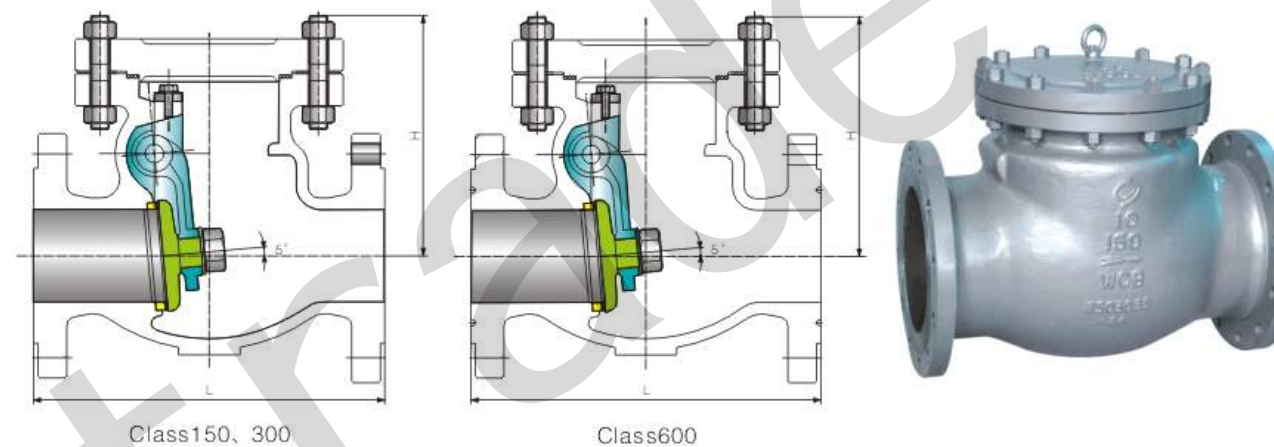
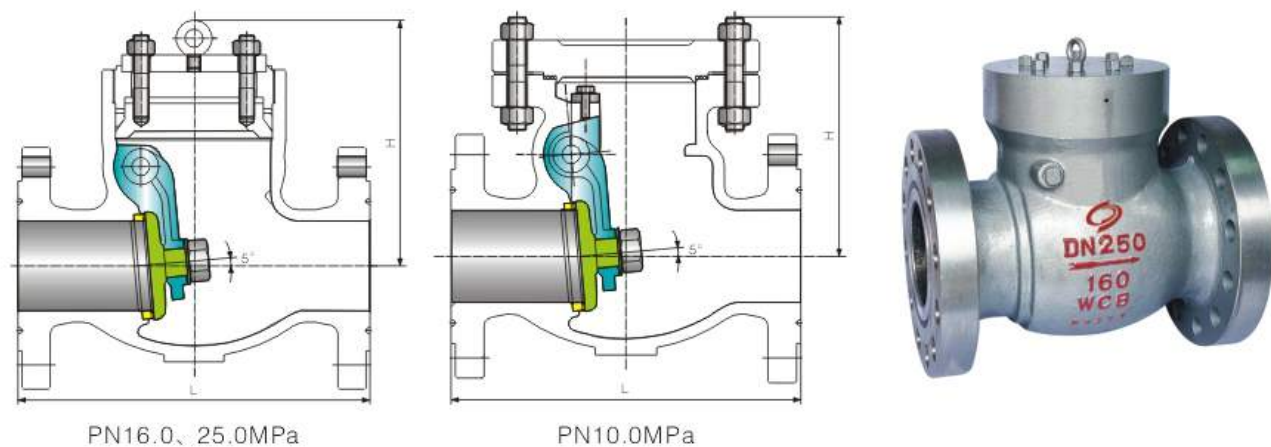

● 主要外形尺寸及重量 Main size of outside & weight

型号Model: H44H、H44Y

PN (MPa)	DN (mm)	尺寸 Dimensions (mm)		重量 Weight (kg)
		L	H	
10.0	50	300	195	43
	65	340	213	52
	80	380	240	75
	100	430	270	112
	150	550	365	220
	200	650	425	345
16.0	250	775	486	475
	50	300	255	52
	65	340	285	62
	80	380	324	113
	100	430	359	165
	150	550	433	270
25.0	200	650	478	324
	250	750	520	375
	50	368	315	65
	65	419	348	79
	80	470	386	95
	100	546	410	172
	150	705	565	275
	200	832	320	325
	250	991	676	395

● 主要外形尺寸及重量 Main size of outside & weight

型号Model: H44H、H44Y

Class	DN (mm)	NPS (in)	尺寸 Dimensions (mm)		重量 Weight (kg)
			L	H	
150	50	2	203	165	17
	65	2 1/2	216	182	26
	80	3	241	195	32
	100	4	292	208	45
	150	6	356	260	75
	200	8	495	295	135
	250	10	622	350	200
	300	12	699	405	275
	350	14	787	446	385
	400	16	864	493	442
300	450	18	978	515	630
	500	20	978	540	760
	50	2	267	175	22
	65	2 1/2	292	186	24
	80	3	318	212	38
	100	4	356	238	52
	150	6	444	302	86
	200	8	533	362	165
	250	10	622	392	204
	300	12	711	440	278
600	350	14	838	460	402
	400	16	864	530	545
	450	18	978	582	683
	500	20	1016	615	862
	50	2	295	200	32
	65	2 1/2	334	219	42
	80	3	359	232	61
	100	4	435	282	112
	150	6	562	330	205
	200	8	664	378	385
250	10	791	452	575	
300	12	842	575	775	
350	14	892	590	982	
400	16	991	635	1056	

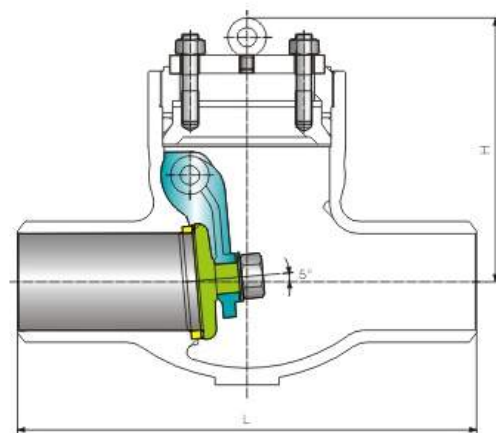

Class600, 900, 1500, 2500



● 主要外形尺寸及重量 Main size of outside & weight

型号Model: (Ps)H64H、(Ps)H64Y

Class	DN (mm)	NPS (in)	尺寸 Dimensions (mm)		重量 Weight (kg)
			L	H	
600	50	2	292	225	29
	65	2 1/2	330	240	35
	80	3	356	254	48
	100	4	432	279	67
	150	6	559	368	110
	200	8	660	393	205
	250	10	787	457	325
	300	12	838	584	480
	350	14	889	609	600
	400	16	991	685	800
	450	18	1092	736	1490
	500	20	1194	762	1675
900	600	24	1397	889	2300
	50	2	368	225	48
	65	2 1/2	419	240	65
	80	3	381	254	70
	100	4	457	279	100
	150	6	610	381	245
	200	8	737	533	425
	250	10	838	558	675
	300	12	965	609	900
	350	14	1029	736	1125
	400	16	1130	762	1600
	450	18	1219	863	2000
500	20	1549	939	2700	
600	24	1549	1066	3500	

Class	DN (mm)	NPS (in)	尺寸 Dimensions (mm)		重量 Weight (kg)
			L	H	
1500	50	2	368	225	48
	65	2 1/2	419	240	65
	80	3	470	254	90
	100	4	546	279	115
	150	6	705	405	250
	200	8	832	567	470
	250	10	991	585	800
	300	12	1130	630	1350
	350	14	1257	750	1800
	400	16	1384	787	2200
	450	18	1537	885	2600
	500	20	1664	960	2700
2500	600	24	1943	1120	4100
	50	2	451	225	80
	65	2 1/2	508	249	102
	80	3	578	254	120
	100	4	673	279	220
	150	6	914	420	540
	200	8	1022	570	920
	250	10	1270	1010	1692
	300	12	1422	1160	2296

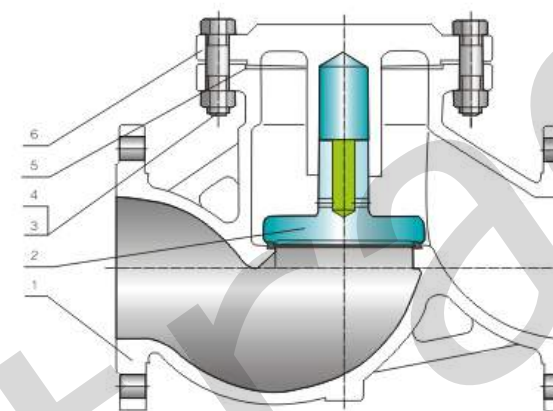

● 产品采用标准 Technical specification

结构形式 Structural formation	螺旋壳盖升降式止回阀 Spiral shell's post bonnet lifting type check valve	
设计依据 Design reference	GB	API
设计标准 Design standard	GB/T 12235	BS1868
结构长度 Face to face	GB/T 12221	ASME B16.10
连接法兰 Flanged ends	JB/T 79-94	ASME B16.5
试验和检验 Test & inspection	JB/T9092	API 598

注：阀门连接法兰及对焊端尺寸可根据用户要求设计制造。
Notes: The sizes of valve connecting flange and butt-welding terminas can be designed according to customer's requirement.

● 主要零件材料 Major parts material form

序号 No.	零件名称 Part name	材质 Material	
		ASTM	GB
1	阀体 Body	WCB, WC1, WC6, WC9, C5 CF8, CF8M, CF8C, CF3, CF3M	WCB, WC1, WC6, WC9, C5 CF8, CF8M, CF8C, CF3, CF3M
2	阀瓣 Disc	WCB, WC1, WC6, WC9, C5 CF8, CF8M, CF8C, CF3, CF3M	WCB, WC1, WC6, WC9, C5 CF8, CF8M, CF8C, CF3, CF3M
3	双头螺柱 Stud	A193-B7, A320-B8, A193-B8M	35CrMoA, 25Cr2MoV, 0Cr18Ni9, 0Cr17Ni12Mo2
4	六角螺母 Six angle nuts	A194-2H, A194-8, A194-8M	45, 35CrMoA, 25Cr2MoV, 0Cr18Ni9, 0Cr17Ni12Mo2
5	垫片 Gasket	柔性石墨+不锈钢 Graphite & stainless steel	柔性石墨+不锈钢 Graphite & stainless steel
6	阀盖 Bonnet	A105, F11, F22, F5, F9 F304, F316, F321, F304L, F316L	25, 1Cr18Ni9Ti, 0Cr18Ni12Mo2Ti 20Cr1Mo1V, 25Cr2MoV

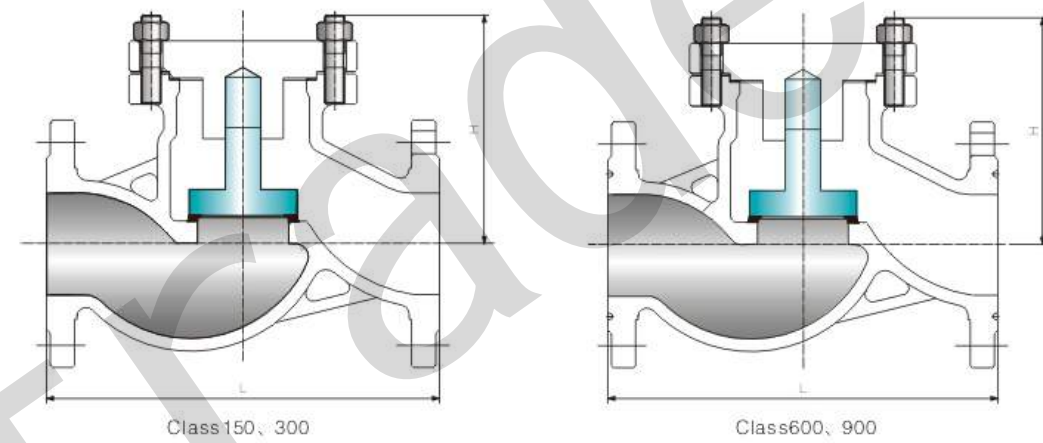
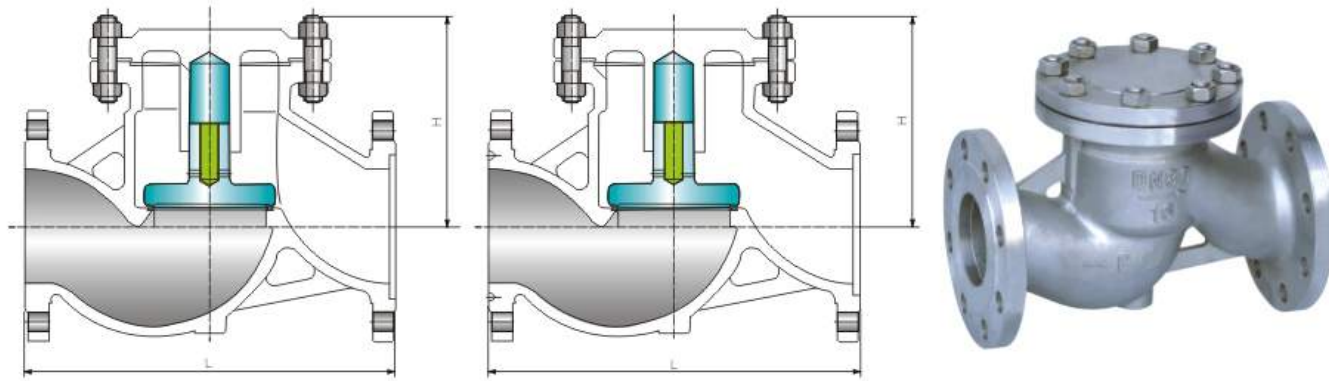

● 主要外形尺寸及重量 Main size of outside & weight

型号Model: H41H、H41Y

PN (MPa)	DN (mm)	尺寸 Dimensions (mm)		重量 Weight (kg)	PN (MPa)	DN (mm)	尺寸 Dimensions (mm)		重量 Weight (kg)
		L	H				L	H	
1.6	50	230	115	20	6.4	50	300	175	30
	65	290	140	24		65	340	190	36
	80	310	175	30		80	380	208	48
	100	350	203	42		100	430	230	70
	125	400	228	59		125	500	265	102
	150	480	250	84		150	550	312	145
	200	600	285	100		200	600	353	198
2.5	50	230	115	21	10.0	50	300	175	30
	65	290	140	25		65	340	193	43
	80	310	175	31		80	380	238	65
	100	350	203	42		100	430	269	89
	125	400	228	60		125	500	313	102
	150	480	250	86		150	550	355	123
	200	600	285	102		200	600	403	148
4.0	50	230	150	17	16.0	50	300	175	32
	65	290	160	22		65	340	193	46
	80	310	178	34		80	380	238	240
	100	350	203	42		100	430	269	273
	125	400	228	75					
	150	480	265	105					
	200	600	317	150					

● 主要外形尺寸及重量 Main size of outside & weight

型号Model: H41H、H41Y

Class	DN (mm)	NPS (in)	尺寸 Dimensions (mm)		重量 Weight (kg)	Class	DN (mm)	NPS (in)	尺寸 Dimensions (mm)		重量 Weight (kg)
			L	H					L	H	
150	50	2	203	165	17	600	50	2	295	210	33
	65	2 1/2	216	175	25		65	2 1/2	334	230	43
	80	3	241	190	29		80	3	359	255	62
	100	4	292	215	50		100	4	435	295	113
	150	6	356	265	85		150	6	562	365	222
	200	8	495	320	150		200	8	664	420	390
	250	10	622	365	240		250	10	791	505	630
300	300	12	698	415	350	900	300	12	842	545	871
	50	2	267	190	28		50	2	372	235	120
	65	2 1/2	292	205	33		65	2 1/2	422	270	166
	80	3	318	220	45		80	3	384	302	176
	100	4	356	245	70		100	4	460	342	182
	150	6	444	295	150		150	6	613	425	403
	200	8	533	330	230						
250	10	622	420	390							
300	12	711	480	520							

● 产品采用标准 Technical specification

设计标准 Design standard	JB/T 3595
结构长度 Structural length	JB/T 2766、GB/T 15188.1
对焊连接 Welded connection	JB/T 2766、GB/T 15188.1
压力与温度 Pressure and temperature	JB/T 3595
试验和检验 Test & inspection	JB/T 3595
焊接坡口 Weld the slope mouth	JB/T 3595、ASME 16.25

注：阀门连接法兰及焊接坡口可根据用户要求设计制造。
Note: valve connecting flange and welded groove can be designed and made upon the user requirements.

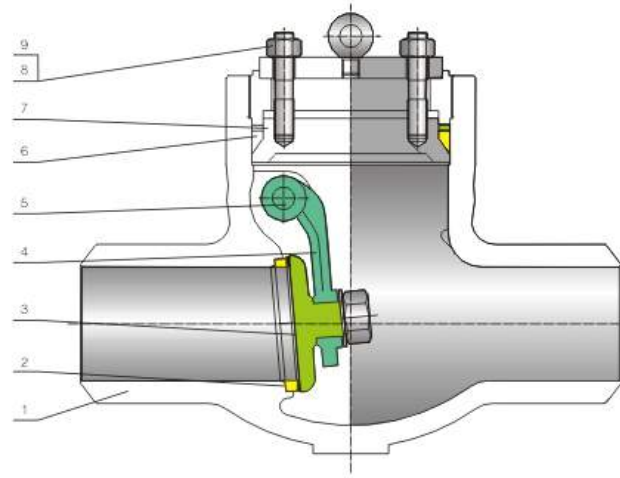

● 主要零件材料 Major parts material form

序号 No.	零件名称 Part name	材质 Material
1	阀体 Body	WCB、WC1、WC6、WC9
2	阀座 Seat	A105、25、15CrMoA、12CrMoVA
3	阀瓣 Disc	A105、25、12CrMoVA
4	摇杆 Rocker	WCB、WC1、WC6、WC9
5	销柱 Sell the post	A105、25、15CrMoA、12CrMoVA
6	密封圈 Sealing ring	柔性石墨 Graphite
7	阀盖 Bonnet	WCB、WC1、WC6、WC9
8	双头螺柱	35CrMoA、25Cr2MoV
9	螺母 Nut	35CrMoA、25Cr2MoV

● 主要外形尺寸及重量 Main size of outside & weight

型号 Model: H64Y-1500Lb、H64Y-2000Lb、H64Y-2500Lb

NPS (in)	1500Lb				2000Lb				2500Lb			
	L	d	H	重量(kg) Weight	L	d	H	重量(kg) Weight	L	d	H	重量(kg) Weight
2 1/2	254	55	282	45	330	50	240	40	-	-	-	-
3	305	64	274	50	368	60	305	60	368	54	297	44
4	406	84	350	80	457	80	315	95	457	70	385	110
5	483	100	425	115	533	96	409	170	533	86	403	168
6	559	126	400	180	610	118	465	186	610	104	455	192
8	711	158	490	270	762	147	528	415	762	130	557	456
10	864	200	540	430	914	180	613	658	914	162	615	730
12	991	250	650	630	1041	222	660	1200	1041	210	715	1120
14	1067	280	710	1400	1118	254	745	1638	1118	234	790	1495
16	-	-	-	-	-	-	-	-	1245	264	815	1950
18	-	-	-	-	-	-	-	-	1397	304	815	2400

● 型号 Model

对焊连接 Welded connection	公称压力(MPa) Nominal pressure	产品型号 Products Model	
JB/T3595 GB/T12224 DL/T531	10.0	H41H-100	-
	20.0	H61Y-200	H61Y-P54100V
	25.0	H61Y-250	H61Y-P54140V
	32.0	H61Y-320	H61Y-P54170V
	45.0	-	H61Y-P57170V

● 用途 Application

焊接连接的止回阀适用于公称压力PN 10.0-45.0MPa, 工作温度≤540℃(其中P57170V工作的温度≤570℃)的石油、化工、火力电站等各种系统的管路上。适用介质为: 水、油品、蒸汽等。

Welding check valve connected to apply to the Nominal pressure PN 10.0-45.0MPa, temperature ≤ 540 °C (which P57170V the temperature of ≤ 570 °C) of oil, chemical, fire station, and other systems of the road.
Suitable medium: water, oil, steam etc.

● 产品采用标准 Technical specification

设计与制造 Design and manufacture	结构长度 Face to face	压力-温度等级 Pressure temperature rating	检验与试验 Inspection & test	供货 Availability
JIS E101 JB/T3595 DL/T531	JIS E101 JB/T3595 GB/T15188.1	JIS E101 JB/T3595	JIS E101 JB/T9092	JB/T7928 GB/T12220

● 性能规范 Technical specification

型号 Model	公称压力 Nominal pressure (Mpa)	试验压力 Test pressure (MPa)		工作温度 Working temperature	适用介质 Applicable medium
		强度试验 Shell test	密封试验 Seat Test		
H61Y-250	25	37.5	27.5	≤425	水、蒸汽、油品
H61Y-320	32	48	35.2		
H61Y-P54140V	P54140V	42	15.4	≤540	
H61Y-P54170V	P54170V	48	18.7		
H61Y-P57170V	P57170V	63	18.7	≤570	

● 主要零件材料及主要用途 Major parts material form & application

型号 Model	阀体 Body	阀盖 Bonnet	阀瓣 Disc	阀座 Seat	填料 Packing	适用介质 Applicable medium	工作温度 Working temperature (≤℃)
H61Y-(320)	A105	A105	2Cr13+Stellite12	2Cr13+Stellite6	柔性石墨	水、蒸汽	425
H61Y-P57(170)V	12Cr1MoV	12Cr1MoV	12Cr1MoV+Stellite12	12Cr1MoV+Stellite6	柔性石墨	蒸汽	570

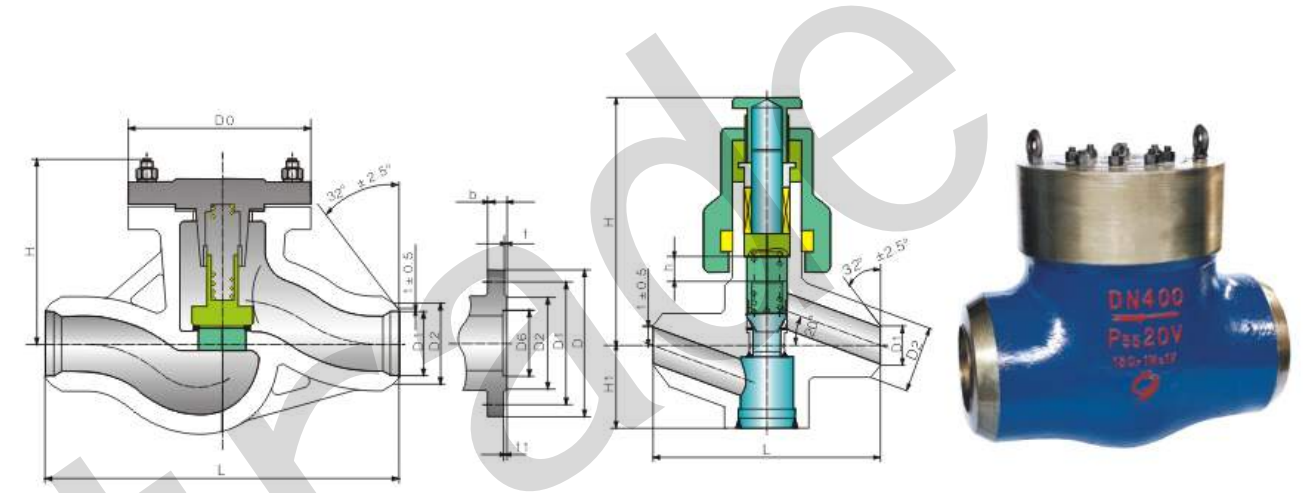

● 结构与特点 Structure and characteristics

- 1、产品设计制造按JIS E101和JB/T3595标准规定, 结构合理, 性能优良, 造型美观。
- 2、阀门中腔静密封采用压力自紧式密封结构, 介质压力越高, 密封性能越好。
- 3、焊接端尺寸严格按JB/T3595、GB/T12224,也可按用户要求加工。
- 4、阀瓣和阀座密封面采用司太立 (stellite) 钴基硬质合金堆焊而成, 耐磨、耐高温、耐腐蚀, 抗擦伤性能好, 使用寿命长。
- 5、高温高压部件采用优质耐热合金钢制造, 安全可靠, 性能稳定。

- 1, product design and manufacturing by JIS E 101 and JB/T3595 standards require that the rational structure, excellent performance, handsome in appearance.
- 2, valves in a sealed chamber static pressure since the tight-sealed structure, the higher the pressure on the media, the better sealing performance.
- 3, welding-size strictly in accordance with JB/T3595, GB/T12224, user requirements can also be processed.
- 4, valve seats and valve sealing surface by the Secretary for too legislature (stellite) from surfacing drill-carbide, wear-resistant, high temperature, corrosion resistance, abrasion resistance performance, and long life.
- 5, high temperature and high pressure components using heat-resistant alloy steel manufacturing high-quality, safe and reliable, stable performance.

● 主要外形尺寸及重量 Main size of outside & weight

H61Y (锻钢型 Forged steel type)

公称压力 PN(Mpa) Nominal pressure	公称通径 DN(mm) Nominal diameter	标准值(mm) Standard values			参考值(mm) Reference values			
		L	D1	D2	h	H	H1	重量 Weight (kg)
32	20	150	20	35	12	153	47	3.91
P5417V	20	150	20	35	17	153	47	4.61
32	25	180	22	52	19	200	66	8
32	32	180	29	52	24	189	65	7.5
20	50	320 350	64	80	33	254	75	25

● 主要外形尺寸及重量 Main size of outside & weight

H61Y (锻钢型自紧式 Forged steel type since the bear)

公称压力 PN(Mpa) Nominal pressure	公称口径 DN(mm) Nominal diameter	标准值(mm) Standard values			参考值(mm) Reference values	
		L	D1	D2	H	重量 Weight (kg)
25 32 P5414V P5417V P5717	10	120	10	20	156	2.5
	15	170	14	26	200	8.5
	20	170	20	32	210	9
	25	170	22	36	210	10
	32	200	32	46	245	14
	40	230	36	52	270	21
	50	250	52	80	300	28

H61Y(铸钢型 Cast steel type)

型号 Model	公称压力 PN(Mpa) Nominal pressure	公称口径 DN(mm) Nominal diameter	标准值(mm) Standard values			参考值(mm) Reference values		
			L	D1	D2	D0	H	重量 Weight (kg)
H61Y-200	20	100	600	113	138	330	290	146
H61Y-320	32	125	900	153	159	400	440	511
H61Y-200	20	175	900	187	222	426	400	410
H61Y-200	20	225	1000	233	273	510	520	570

● 用途 Application

该阀门适用于电站及工业管道系统上, 作锅炉再热器、过热器及管道或其它设备进行水压试验的装置。适用介质: 水、蒸气
The Valve is used in power station and industrial pipeline system as water pressure test device for Reheater, Superheater, Pipelines and other equipment. Suitable Medium: Water, Steam

● 型号编制说明 Introduction of model figure system



● 性能规范 Technical specification

产品型号 Product Model	公称压力 Nominal pressure	强度试验压力 Shell test Pressure	密封试验压力 Seat Test Pressure	工作温度下的最大工作压力 (Mpa) Max working pressure at working temperature			
				38°C	350°C	425°C	540°C
JTSY6BW JTSY6BWG	600	15.65	11.44	10.4	7.5	5.8	
JTSY9BWL2 JTSY9BWL2G	900	23.7	6.15	15.8	12.0	10.7	5.6
JTSY25BWL2	2500	65.9	17.0	43.9	34.5	29.7	15.4
JTSY30BWL2	3000	79.1	20.3	52.7	41.4	35.7	18.45

● 主要零件材料 Material for main parts

零件名称 Part name	JTSY6BW	JTSY6BWG	JTSY9BWL2	JTSY9BWL2G	JTSY9BWL2G	JTSY30BWL2
阀体、阀盖、导 管、阀瓣 Body, Bonnet, Conduit, Disk	WCB			WC9		
堵板 Plate	25					
顶柱 Screw Stem	1Cr17Ni2					
垫片 (密封环) Gasket	1Cr13/XB 450			纯铁/ Soft Iron		
阀座 Seat Ring	橡胶 Rubber					
支架 Yoke	WCB					
阀杆 Stem	2Cr13			20Cr1MoV1A		
填料 Packing	柔性石墨 Flexible Graphite			增强柔性石墨 Reinforced Flexible Graphite		

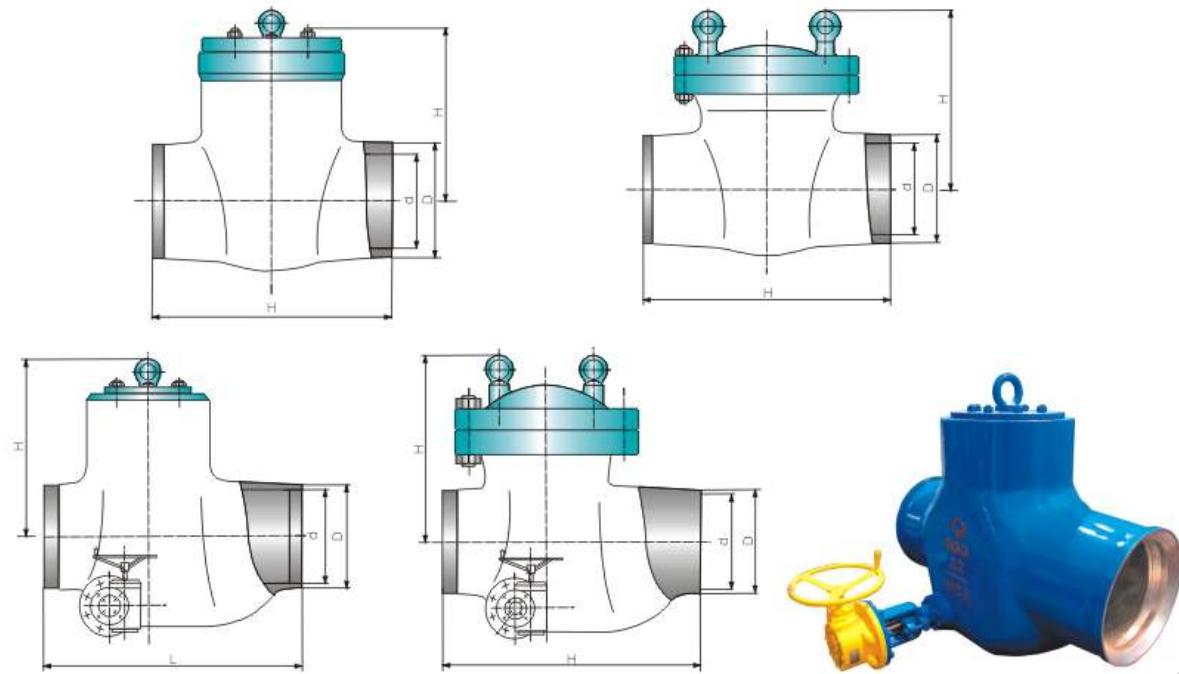

● 主要外形尺寸及重量 Main size of outside & weight

型号 Model	口径 NPS (in)	外形尺寸 Overall dimensions				重量 (Kg) Weight
		L	d	D	H	
JTSY6BW	16	991	386	432	730	1130
	22	1295	500	586	655	1800
JTSY6BWG	22	1295	500	584	700	1880
	34	1753	778	882	1044	4928
JTSY9BWL2	22	1200	476	570	850	2274
	28	1753	608	762	1012	3938
JTSY9BWL2G	22	1445	476	570	910	2150
	28	1753	608	762	1007	4060
JTSY25BWL2	16	1245	255	405	690	1965
JTSY30BWL2	22	1499	330	580	970	4500

● 用途 Application

该阀门适用于电站汽轮机的给水预热系统或其它要求快速关闭的工业管线系统，在气源压力（0.5~0.7Mpa）或回位弹簧的作用下迅速关闭（关闭时间≤0.5s）以防止介质倒流损坏汽轮机和其它装置。

适用介质：水、蒸气

The valve is used in feed water preheating system of steam turbine in power station or other industrial pipeline system requiring fast close. It can fastclose with air pressure (0.5~0.7Mpa) or return spring (close time less than 0.5 second) to prevent medium from reverse flow and steam turbine and other device from damage.

Suitable medium: Water, Steam

● 主要性能规范 Main technical specification

型号 Model	公称压力 Pressure Class	强度试验压力 Shell test Pressure	密封试验压力 Seat Test Pressure
	Mpa	Mpa	Mpa
NH664H-20	2.0	3.0	2.20
NH664H-50	5.0	7.5	5.50
NH664H-100 NH664Y-100C6	10.0	15.5	11.0

● 压力温度基准 Pressure-temperature ratings

型号 Model	工作温度 Working temperature °C									
	38	200	260	316	371	399	427	454	500	540
NH664H-20	2.0	1.4	1.2	1.0	0.9	0.65	0.55			
NH664H-50	5.1	4.4	4.2	3.9	3.75	3.55	2.9			
NH664H-100	10.2	8.5	8.5	7.7	7.5	7.1	5.8	6.85	5.5	
NH664Y-100C6	10.3	9.3	9.0	8.2	8.0	7.5	7.1			3.0

● 主要零件材料 Material for main parts

零件名称 Part name	NH664H-20 NH664H-50 100	NH664Y-100C6
阀体、阀瓣、阀盖、摇杆 Body, Disk, Bonnet, Hinge Pin	WCB	WC6
轴 Shaft	2Cr13	20Cr1Mo1V1A
中法兰螺栓 Bolt/Nut	35/45	20Cr1Mo1V1A/45

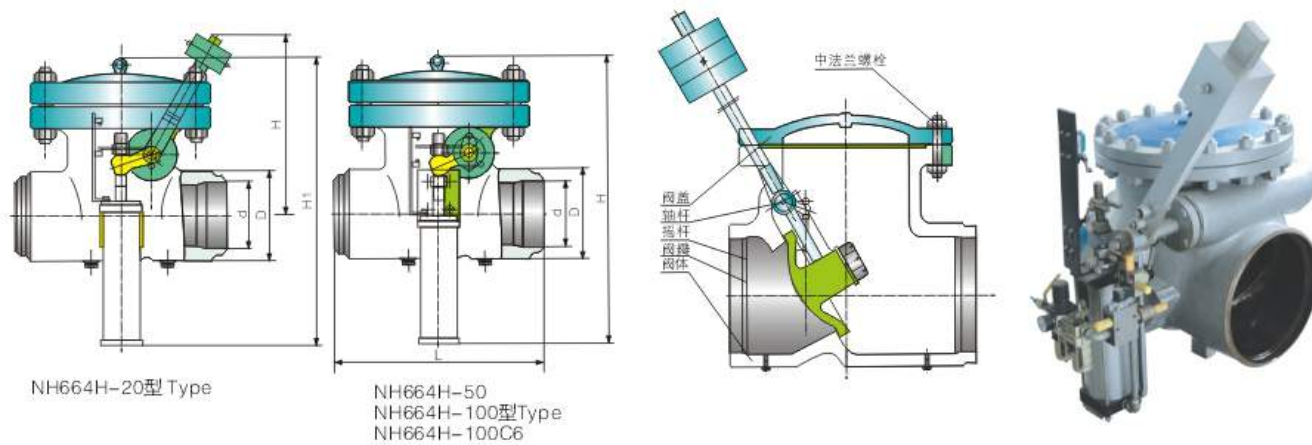

● 主要外形尺寸及重量 Main size of outside & weight

口径 Size (mm)	外形尺寸Overall Dimension(mm)					重量Weight (Kg)
	L	d	D	H	H1	
450	740	428	482	990	755	625
500	790	478	532	990	852	760
600	915	574	634	990	1150	1080
700	1040	678	726	990	1240	1250

口径 Size (mm)	外形尺寸Overall Dimension(mm)				重量Weight (Kg)
	L	D	D	H	
200	526	198	248	815	240
300	610	296	332	845	360
350	838	332	380	889	620

口径 Size (mm)	外形尺寸Overall Dimension(mm)				重量Weight (Kg)
	L	d	D	H	
250	680	236	302	904	390
500	1020	478	532	1240	1490

口径 Size (mm)	外形尺寸Overall Dimension(mm)				重量Weight (Kg)
	L	d	D	H	
250	526	188	248	815	280
500	680	236	302	904	390

● 产品采用标准 Technical specification

设计与制造 Design and manufacture	JB/T3595 GB/T12224	
连接端尺寸 Connectors Size	结构长度 Face to face	Jb96
	法兰尺寸 Flange size	Jb79
检验与试验 Inspection & test	JB/T3595 JB/T9092	
材料Material	碳钢 Carbon steel	GB/T12290
	不锈钢 Stainless steel	GB/T12230
标志 Mark	GB/T12220	
供货 Availability	JB/T7928	

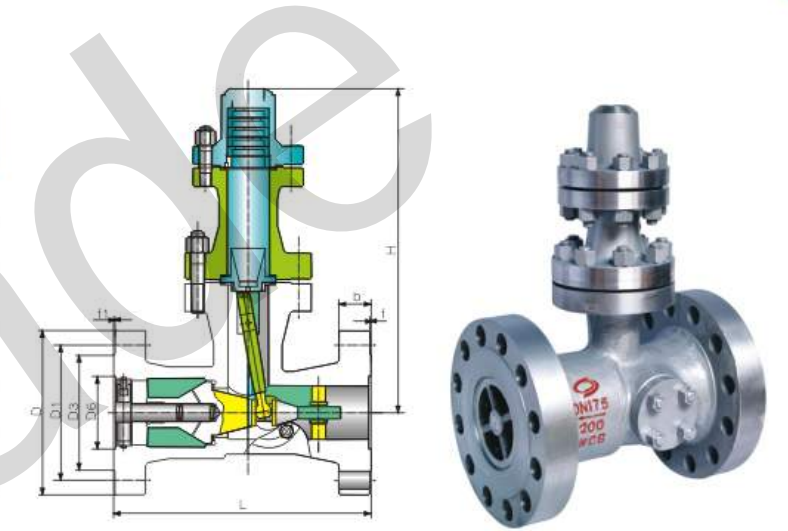

● 主要零件材料 Material for main parts

序号 No.	零件名称 Part name	材质 Material	
		H48H-200型	H48W-200P型
1	阀体 Body	WCB	ZG1Cr18Ni9Ti
2	连接法兰 Flange connection	WCB	ZG1Cr18Ni9Ti
3	定位轮 Positioning round	WCB	ZG1Cr18Ni9Ti
4	排气法兰 Exhaust flange	WCB	ZG1Cr18Ni9Ti
5	法兰盖 Cover flange	A105	ZG1Cr18Ni9Ti
6	弹簧 Spring	30W4Cr2VA	17-7PH
7	阀瓣 Disc	2Cr13	ZG1Cr18Ni9Ti
8	滑块 Slider	2Cr13	1Cr17Ni2
9	拨叉 Fork	2Cr13	1Cr17Ni2
10	排放套 Sets emission	ZG2Cr13	ZG1Cr18Ni9Ti
11	螺柱 Stud	35CrMoA	1Cr17Ni2
12	衬套 Bushing	ZQA19-4	ZQA19-4

● 主要性能规范 Main technical specification

试验压力 Test pressure (MPa)	强度试验 Shell test(MPa)	密封试验 Seat Test(MPa)	适用温度(°C) Working temperature	适用介质 Applicable medium
20.0	30.0	20.0	≤160	水、蒸气 Water, steam

● 主要外形尺寸及重量 Main size of outside & weight

公称压力 PN(Mpa) Nominal pressure	公称通径 DN(mm) Nominal diameter	标准值(mm) Standard values									参考值(mm) Reference values	
		L	D	D1	D2	D6	b	f	f1	Z-Φd	H	重量 Weight (kg)
20.0	125	610	385	318	270	170	76	3	5	12-Φ41	761	508
20.0	175	610	475	394	340	214	84	3	6	12-Φ48	761	580

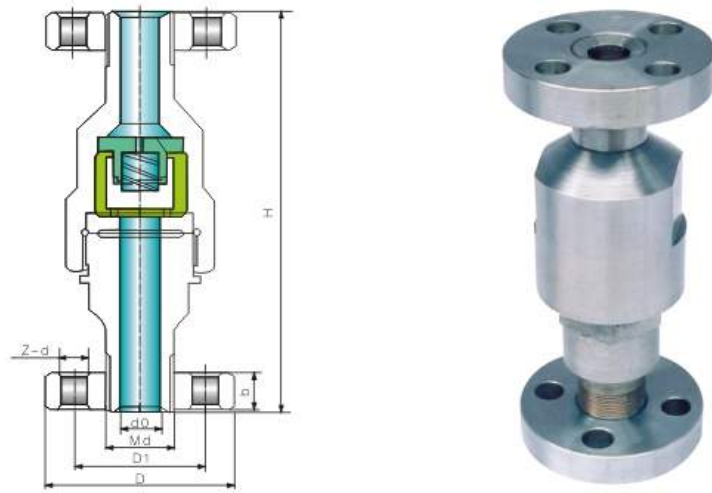

● 主要外形尺寸及重量 Main size of outside & weight

H42Y-PN16.0~32.0

公称压力 Nominal pressure PN(MPa)	DN	D0	D	D1	Md	Z-d	H	b	WT (Kg)
16.0MPa	15	15	95	60	M24×2	3-18	240	20	5.5
	25	23	105	68	M33×2	3-18	262	20	7.5
	32	29	115	80	M42×2	4-18	285	22	10
	40	39	165	115	M52×2	6-26	285	28	19.5
32.0MPa	10	11	95	60	M24×2	3-18	234	20	5.5
	15	17	105	68	M33×2	3-18	240	20	6
	25	23	115	80	M42×2	4-18	262	22	8.5
	32	29	135	95	M48×2	4-22	285	25	12
	40	42	165	115	M64×2	6-26	316	32	21



● 主要外形尺寸及重量 Main size of outside & weight

H72Y-PN16.0MPa~32.0MPa

公称压力 Nominal pressure PN(MPa)	DN	D	M	D2	D0	L0	d	L	WT (Kg)
16.0MPa	15	95	M24×2	20	16	145	42	60	5
	25	105	M33×2	28	23	155	50	65	10
	32	115	M42×2	37	29	175	62	80	15
	40	165	M52×2	42	39	215	72	90	20
	50	165	M64×2	58	50	245	88	115	30
	65	200	M80×2	73	65	300	115	140	45
32.0MPa	80	225	M100×2	93	80	345	135	160	60
	15	105	M33×2	27	17	155	50	65	5
	25	115	M42×2	35	22	175	62	80	10
	32	135	M48×2	41	30	200	72	90	15
	40	165	M60×3	58	42	245	88	115	20
	50	200	M80×3	70	58	300	115	140	30
	65	215	M100×3	90	68	345	135	160	45
	80	260	M125×4	112	85	395	165	185	60

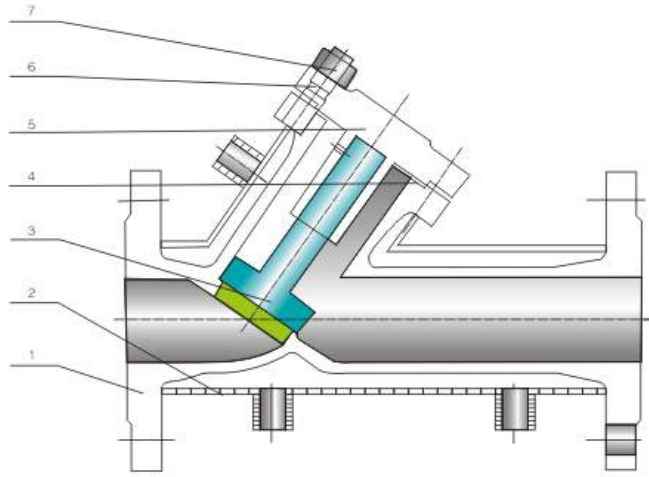

● 产品性能规范 Products performance specification

设计标准 Design Standard	GB/T12235
结构长度 Face to face	GB/T12221
连接法兰 Flanged ends	GB/T9113、JB/T79、HG20596
试验和检验 Test&Inspection	GB/T13927、JB/T9092

注：系列阀门连接法兰尺寸可根据用户要求设计等制造。
Notes: the sizes of serial valve connecting flange can be designed according to customers' requirement.

● 主要零件材料 Major parts material form

序号 NO	零件名称 Part name	材质 Material
1	阀体 Body	WCB、WC6、WC9、C5 CF8、CF8M、CF3、CF3M
2	夹套 Jackcted	25、304
3	阀瓣 Disc	25、1Cr13、2Cr13 1Cr18Ni9Ti、0Cr18Ni12MO2Ti 20Cr1Mo1V、25Cr2MoV
4	垫片 Gasket	柔性石墨+不锈钢 Graphite、Stainless steel、PTFE
5	阀盖 Bonnet	WCB、WC6、WC9、C5 CF8、CF8M、CF3、CF3M
6	双头螺柱 Stud	35CrMoA、0Cr18Ni9、 0Cr17Ni12Mo2、25Cr2MoV
7	六角螺母 Nut	45、35CrMoA、0Cr18Ni9、 0Cr17Ni12Mo2、25Cr2MoV

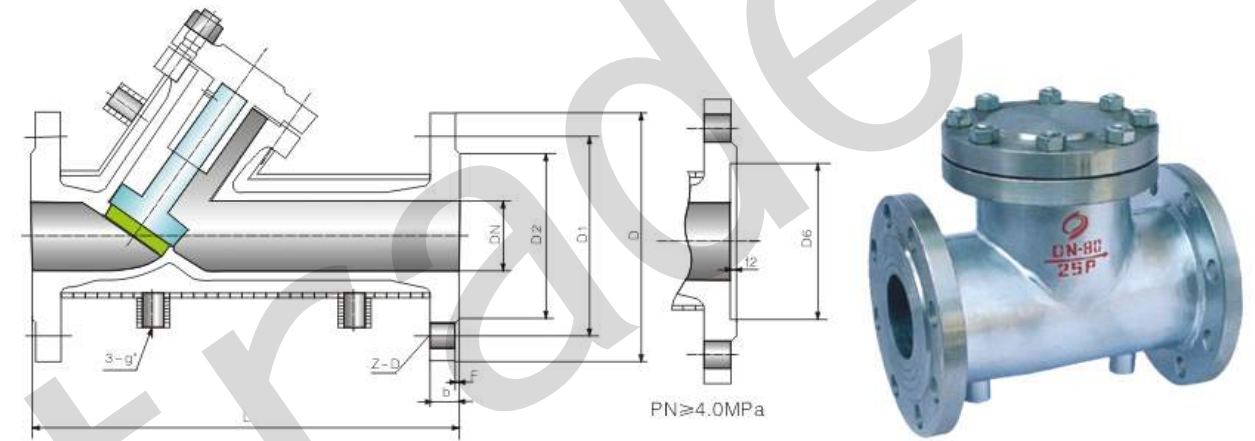

● 主要外形尺寸及重量 Main size of outside & weight

PN2.5-4.0MPa

型号 Model		BH45H(W、Y)-25/40P (R、RL、RL、I、H、V)									
PN(MPa)	DN(mm)	L	D	D1	D2	D6	B	F	F2	Z-d	3-g"
2.5	15	200	105	75	55	-	16	2	-	4-14	1/2"
	20	220	115	85	65	-	16	2	-	4-14	1/2"
	25	220	135	100	78	-	18	2	-	4-18	1/2"
	32	250	145	110	85	-	18	3	-	4-18	1/2"
	40	270	160	125	100	-	20	3	-	4-18	1/2"
	50	300	180	145	120	-	22	3	-	8-18	3/4"
	65	350	195	160	135	-	22	3	-	8-18	3/4"
	80	380	230	190	160	-	24	3	-	8-23	3/4"
	100	430	270	220	188	-	28	3	-	8-25	1"
	125	490	300	250	218	-	30	3	-	8-25	1"
4.0	150	570	330	280	248	-	32	3	-	12-25	1"
	200	590	395	340	302	-	36	3	-	12-30	1"
	15	200	105	75	55	51	16	2	4	4-14	1/2"
	20	220	115	85	65	58	16	2	4	4-14	1/2"
	25	220	135	100	78	66	18	2	4	4-18	1/2"
	32	250	145	110	85	76	18	3	4	4-18	1/2"
	40	270	160	125	100	88	20	3	4	4-18	1/2"
	50	300	180	145	120	110	22	3	4	8-18	3/4"
	65	350	195	160	135	121	22	3	4.5	8-18	3/4"
	80	380	230	190	160	150	24	3	4.5	8-23	3/4"
100	430	270	220	188	176	28	3	4.5	8-25	1"	
125	490	300	250	218	204	30	3	4.5	8-25	1"	
150	570	350	295	258	234	34	3	4.5	12-30	1"	
200	590	415	355	315	287	40	4	4.5	12-34	1"	

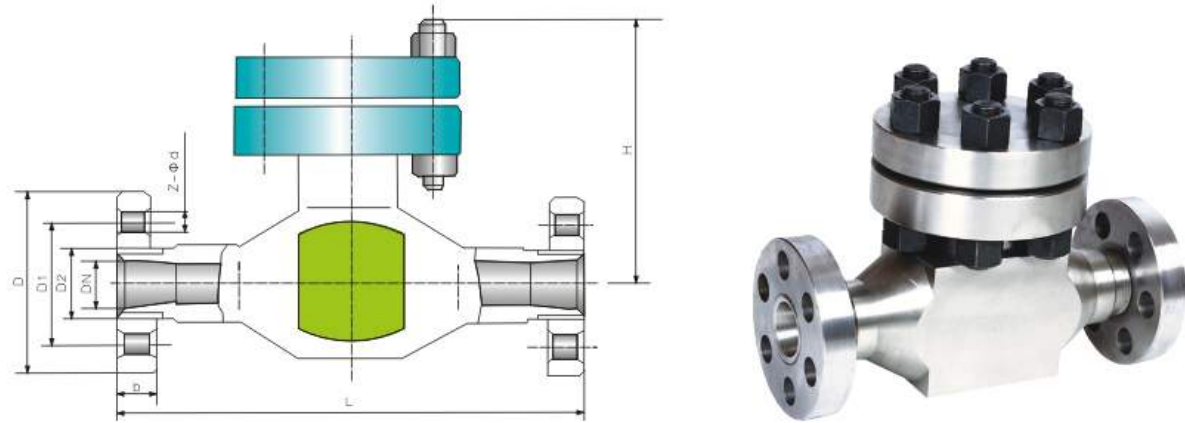

● 结构特点 Structural features

专利产品H4¹/₃WA-220/320Roo是H41W-220/320R的换代产品, 是我公司为尿素合成塔设计的卧式高压止回阀。

H4¹/₃WA-220/320Roo patented product is H41W-220/320R replacement products, is my company for urea reactor design of horizontal high-pressure check valve.

● 技术性能规范 Technical specification

工作温度 Work temperature	195℃	195℃	220℃
阀体材料 Body materials	铬镍钛钢 Chromium nickel-titanium steel	铬镍钛钢 Chromium nickel-titanium steel	工业纯钛 Titanium Industry
应控制温度 Temperature should be controlled	190	190	205
适用介质 Applicable Medium	硝酸类 Nitrate category	尿素醋酸类 Urea acetate category	氧化性腐蚀介质 Oxidative corrosion medium

阀门的检验与试验按JB/T9092-1999的有关规定 Inspection and testing of the valve according to the relevant provisions of JB/T9092-1999

● 主要外形尺寸 Main size of outside

PN16.0-22.0

DN(mm)	L	D	D1	D2	b	Z-Φ	H
40	380	165	115	M52X2	28	6-26	210
50	440	165	115	M64X3	32	6-26	220
65	510	200	145	M85X3	40	6-29	230
80	510	225	170	M100X3	50	6-33	270
100	550	260	195	M125X4	60	6-36	310

● 主要外形尺寸 Main size of outside

PN25.0-32.0

DN(mm)	L	D	D1	D2	b	Z-Φ	H
40	440	165	115	M64X3	32	6-26	220
50	440	200	145	M80X3	40	6-29	230
65	510	225	170	M100X3	50	6-33	240
80	510	260	195	M125X4	60	6-36	280
100	550	300	235	M155X4	75	8-39	320